

connector - with screwless terminals



Product description	
BALS-Prd.-Nr	3126
EAN	4024941031264
Product category	QUICK-CONNECT connector
Current	16A
Number of poles	3p
Arrangement of phases	2P+PE
Position of earth contact	6 h
Voltage	200 - 250V~
Frequency	50/60Hz

Product description	
Protection degree	IP44
Colour code	blue RAL 5015
Colour of appliance	Hinged lid blue RAL 5015, Collar blue RAL 5015, Cable gland grey RAL 7035, Housing cover blue RAL 5015
Connection design	screwless spring terminals with Kontex-Kontakt
Maximum conductor size	2,5 qmm
Cable entry	with cable gland
Height	149mm
Width	53mm
Depth	69mm
Material of enclosure	Polyamide
Contacts	The contacts are brass, The contact carrier is made of polyamide

Additional technical properties	
	MULTI-GRIP cable gland with gasket and integrated strain relief, For cable diameter from 8 up to max. 18 mm, The enclosure components are connected without screws and are secured by a snap-lock mechanism. Opening is only possible with a screwdriver.

Logistics data	
Weight/pcs	0.138 kg / Piece
Packaging	Carton
Content amount	10 ST

Logistics data	
EAN	4024941958264
Length	275 mm
Width	175 mm
Height	137 mm
Weight	1.505 kg
Volume	5,737.5 ccm

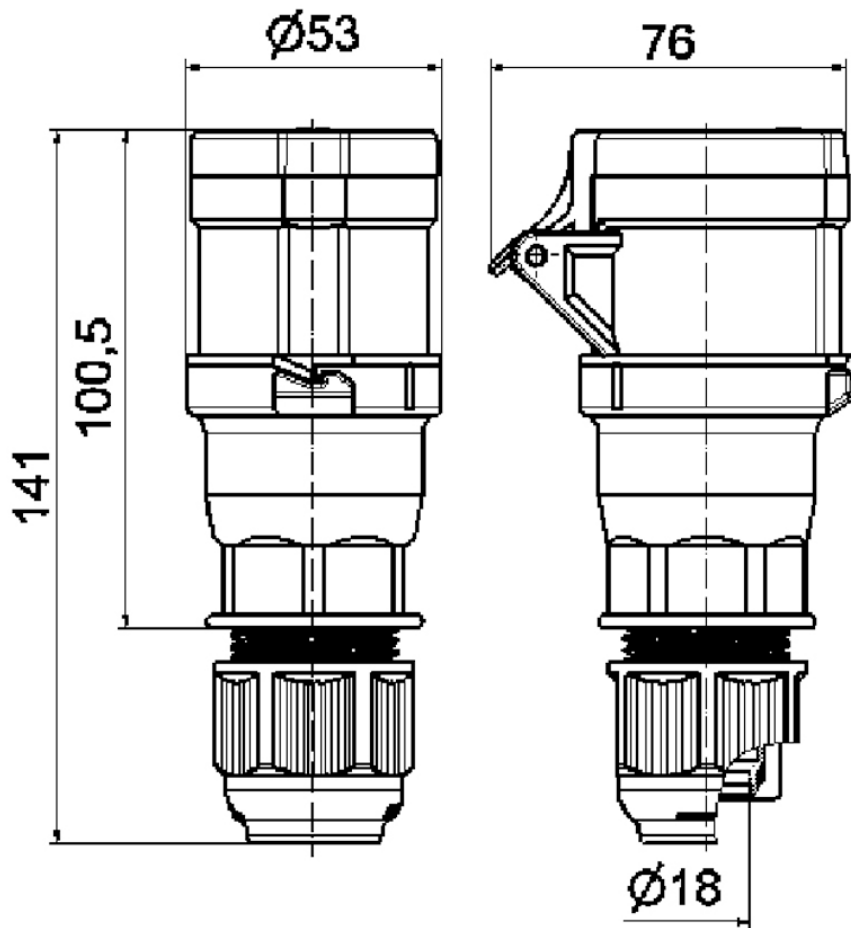

3 MB 110