

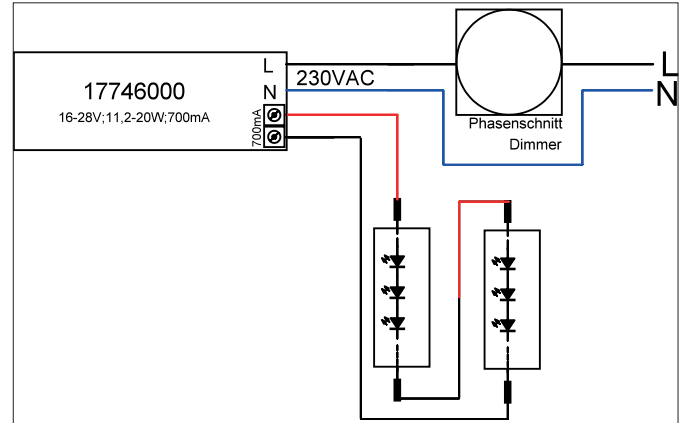

LED converter 700 mA, trailing-edge phase dimmable
 Article no. 17746000

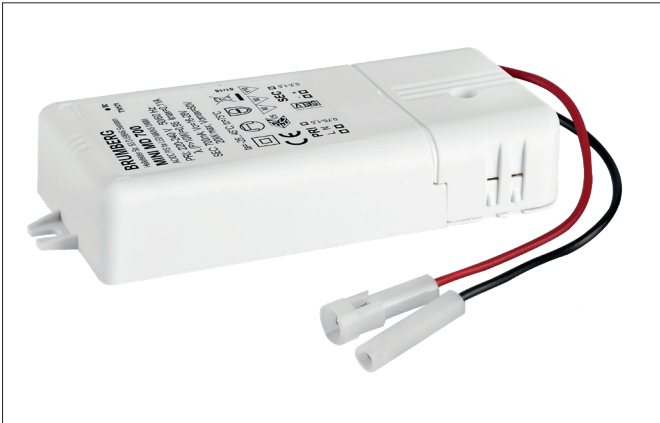

Tender
 LED converter 700 mA, trailing-edge phase dimmable, white, Rectangular. Material: Plastic, Degree of protection: according to DIN EN 60529 IP20, Protection class: (EN 61140) II, Voltage: 230V AC 50Hz, Power: 20 W, Dimmable: Yes, Type of dimming: Trailing-edge phase.

Article data	
Article no.	17746000
GTIN	4251433924067
Short description	LED converter 700 mA, trailing-edge phase dimmable
Material	Plastic
Colour	white
Shape	Rectangular
Length	110.5 mm
Width	52 mm
Hight	22 mm
Scope of delivery	Plug&Play-Ausgangsleitung, Länge 110 mm
Weight	0.113 kg
stamp	ENEC 05, EL
Conformance	CE

LED converter 700 mA, trailing-edge phase dimmable

Article no. 17746000

Operating technology of driver	
AC nominal voltage min	198 V
AC nominal voltage max	264 V
Frequency min	47 Hz
Frequency max	63 Hz
Protection class	II
Degree of protection	IP20
Power	11.2 W
Power max.	20 W
Output_ripple_current	20
Starting current	2 A, 50 μ s
Suitable for emergency lighting	No
measure point (tc)	75 °C
Version	Plug&Play
Power factor	0.95
max. no. lights on B16 A	50
Output voltage max	28.00 V
Output voltage min.	16.00 V
Flicker value Pst LM	1.00
Control	Trailing-edge phase
Number of poles	2
Environment temperature (ta)	-25 °C up to +45 °C
Measure point (tc)	max. +75 °C
Output current	700 mA

Packing data	
Gross weight	0.14 kg
Length of packaging	60 mm
Packaging width	27 mm
Packaging height	150 mm
Disposal at end of life	<p>This product must not be disposed of with household waste. You are obliged, to dispose of such electrical waste separately.</p> <p>By disposing of electrical waste and other old or defective electronics separately, you support recycling or other forms of re-use. In that way you help to take care and to avoid that harmful substances get into the environment.</p>