

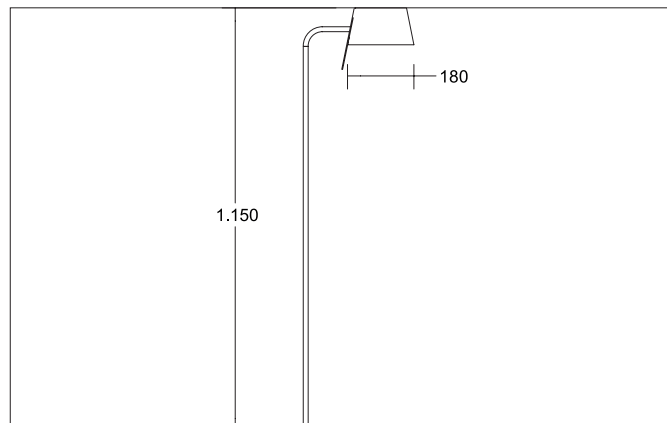

EUGENIA Floor light, with fabric shade

Article no. 58120150

Tender

Floor light, with fabric shade, shade brown / nickel matt, Round. Compact design for harmonious implementation in well-rounded architectural room concepts. Lamp holder: G9, Mounting method: Surface mounting, Place of installation: Floor-mounted, Material: Aluminium / Brass / Iron, Degree of protection: according to DIN EN 60529 IP20, Protection class: (EN 61140) II, Voltage: 230V AC 50Hz, Power: 8 W, Amount of light sources / fittings: 1 piece, Adjustability: Pivoted, without control gear, Type of dimming: Other.

Article data	
Article no.	58120150
GTIN	4251433920779
Series name	EUGENIA
Short description	Floor light, with fabric shade
Material	Aluminium / Brass / Iron
Colour	shade brown / nickel matt
Shape	Round
Outer diameter	430 mm
Hight	1,150 mm
Shade colour	Brown
Shade material	Chintz
Weight	2.783 kg
Conformance	CE, UKCA

**EUGENIA Floor light, with fabric shade**

Article no. 58120150

Operating technology of the luminaire	
Voltage type	AC
AC nominal voltage max	230 V
Frequency max	50 Hz
Lamp	For LED-retrofill lamp
Lamp holder	G9
Protection class	II
Degree of protection	IP20
Control	Other
Bulb change possible	Yes
Energy efficiency class	not required

Mounting technology	
Mounting method	Surface mounting
Place of installation	Floor-mounted
Adjustability	Pivoted

Packing data	
Gross weight	4.5 kg
Length of packaging	1,200 mm
Packaging width	300 mm
Packaging height	450 mm
Disposal at end of life	<p>This product must not be disposed of with household waste. You are obliged, to dispose of such electrical waste separately.</p> <p>By disposing of electrical waste and other old or defective electronics separately, you support recycling or other forms of re-use. In that way you help to take care and to avoid that harmful substances get into the environment.</p>